

Computer system for producing blended wines

Project RESEARCHES REGARDING THE DEVELOPMENT OF A HIGH PERFORMANCE TECHNIQUE FOR DETERMINING BEST RECIPES FOR BLENDING ROMANIAN WINES, ASSISTED BY A EXPERT SYSTEM

M. Blejan , I. A. Feodorov*

*INOE 2000-IHP

Blending is one of the main processes developed for obtaining homogenous wines, with important complementary qualities.

By means of a computerized system it is realized the right dosage on the base of a blending recipe determined by a professional system using data from initial analyses, for obtaining a high quality product. Wines are tasted by a group of authorized experts that will make the eventual rectifications. The professional computerized system undertakes these indications and improves the blending recipe. In the end is obtained a professional open system which will be able to acquire in time necessary data for blending wine sorts specific for each producer.

The article presents an experimental model of a computerized system for producing blended wines which will be tested for showing its performance and usefulness in the technological process of producing blended wines.

The experimental model of the installation for producing blended wines is conceived as a computerized system which receives at entry the measured or appraised parameter values of the wine sorts which compose the blending recipe and provides at exit by means of an automatic scale an amount of wine corresponding to the desired sort of blended wine. Fig.1 shows the functional block scheme of the experimental model.

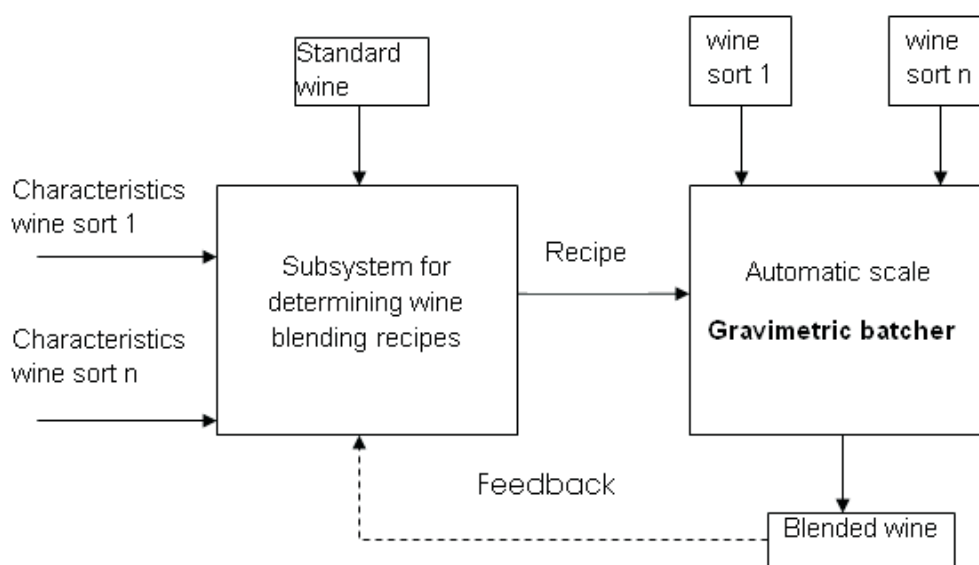

Fig.1 Functional block scheme of the experimental model

The professional system determines on the base of the characteristics of the wine sorts used and the characteristics of the standard wine the blending recipe. This blending recipe is applied to a gravimetric batcher that processes it by blending the wines composing the recipe obtaining in a bin the blended wine. It is possible to induce a feedback reaction by comparing the blended wine with the standard wine, improving in this way the blending recipe.

The experimental model for blending wines consists of a computerized system which will be developed according to the principles of performing multitier distributed applications. These multitier applications represent an architecture used for implementing computerized systems which allow the simultaneous access of more users at the system and the data is separated by the processing programs. An example are the WEB applications.

The interface technological process with the computerized system

The software component parts needed for realizing the communication with the electronic module which provide the control of pumps and electroventils involved in the technological process of blending as well as the receiving of data referring at weight from the automatic scale device and the interface with the subsystem for determining the blending recipes represent parts of the technological process of blending wines, being installed in the computerized system of the beneficiary. The architecture of the communication and data base software is integrated in the computerized system type distributed multitiered applications which means multilevel distributed applications to -fig.2- the computerized system being added a new level, a mechatronic tier which offers improved performances to the computerized system of the beneficiary.

The enterprise information system EIS is the computer system existent at the beneficiary, the user of the mechatronic technology integrating the software components of the mechatronic module to EIS.

The integration in the classical structure of the distributed multitiered applications architecture of the mechatronic tier which integrates the measurement technology developed by the project as mechatronic equipment for gravimetric dosage in the computerized system of the beneficiary allows him to implement integrated computerized monitoring systems for the technological process of production.

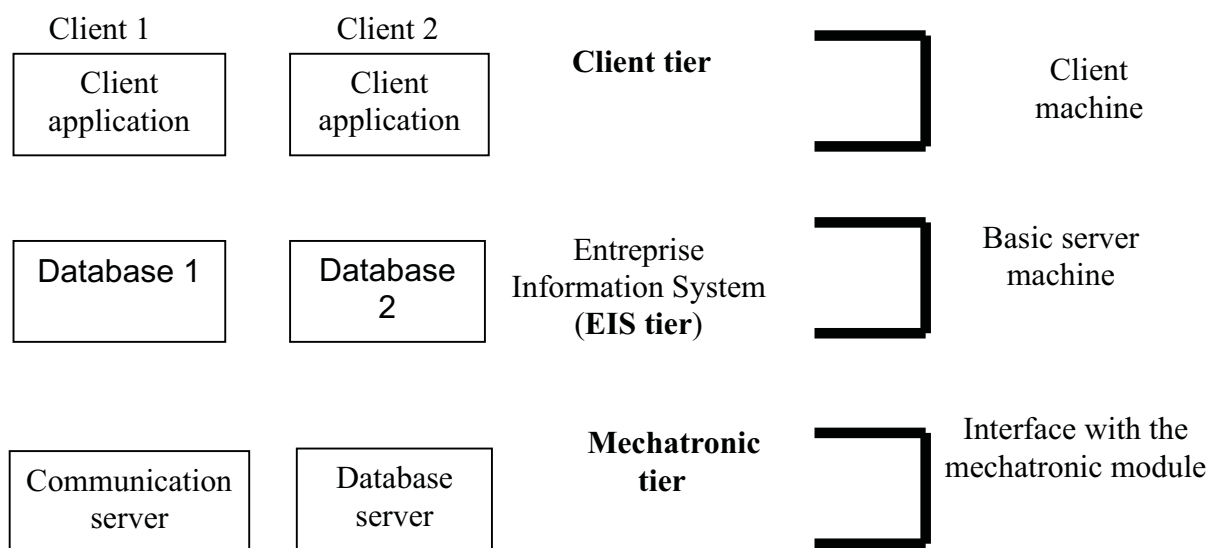

Fig.2 The architecture of the computerized system type distributed multitiered applications

The subsystem for determining blending recipes

In fig.3 is shown the structural and functional scheme of the subsystem for determining the blending recipes. It is emphasized the structure of level EIS see fig.2 implemented on a PC with Windows XP operating system. Are also put into evidence the functional relations between different program modules run on this PC.

In the structure of this subsystem there is a database where are stocked data referring at the parameters of the mathematical model of the blending process, data to be used by the professional system, information about operating the system, reports and analyses which may be accessed by clients from different stages of production or management etc.

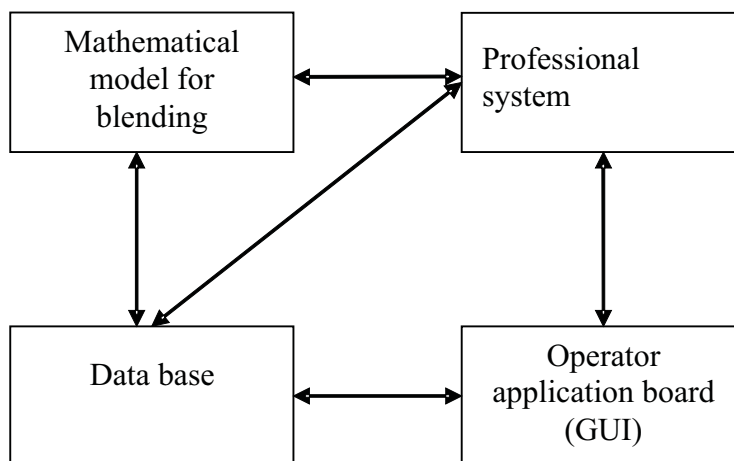

Fig.3 Subsystem for determining blending recipes

The subsystem includes as well the mathematical algorithm for determining the blending recipes which is assisted by a professional system for determining the best recipe. The operator interacts with the application by means of the board being able to see the recipes, introduce data and manage the technological process.

The gravimetric batcher

In fig.4 is shown the block scheme of the gravimetric batcher which is a component of the computerized system used for blending wines.

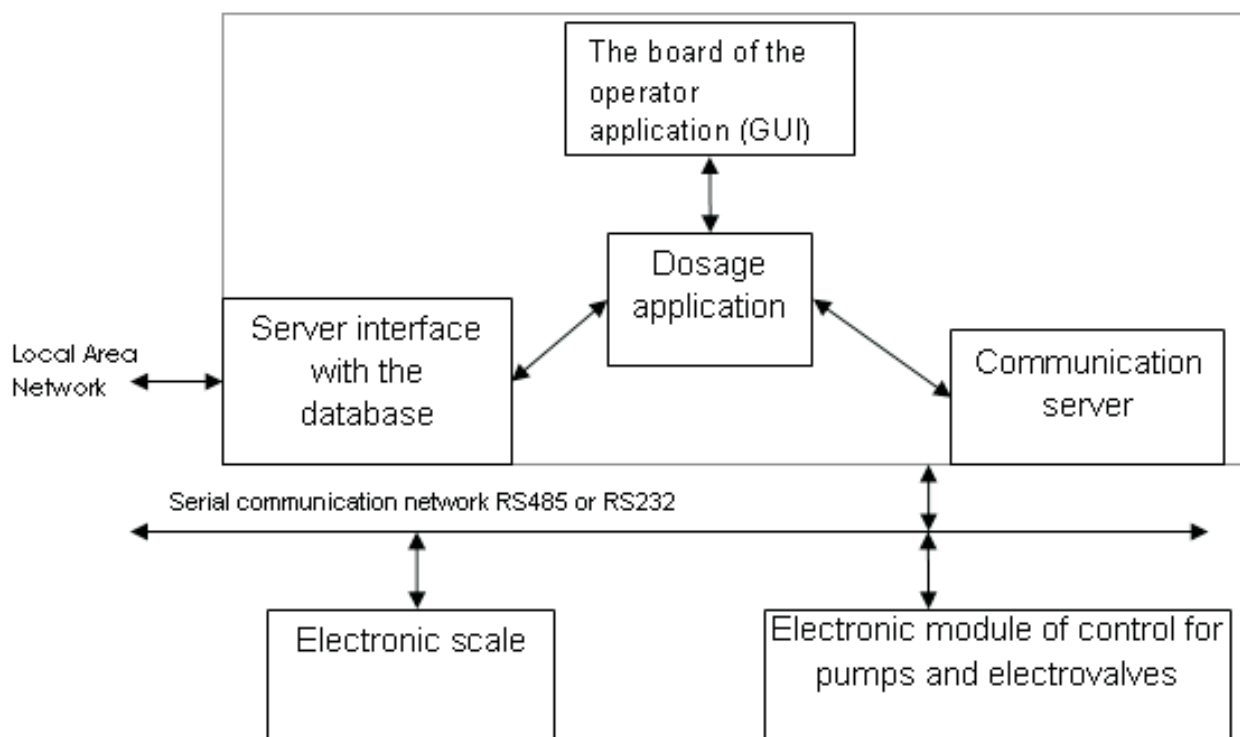

Fig.4 Gravimetric batcher block scheme

The gravimetric batcher is composed of a PC, an electronic scale, an electronic module of control for pumps and electrovalves necessary for the dosing process. The gravimetric dosage is realized by summing up the amounts specified in the blending recipe from each sort of wine mentioned in the recipe. The bin in which is realized the dosage is weighted with the electronic scale this allowing an accurate control of amounts of the recipe. The information referring at the amount measured by the electronic scale is transmitted by means of a serial data communication line to the PC. The management of the serial line is provided by the communication server which implements a communication network type master slave where the computer is the master and the electronic scale and the electronic module of control of the pumps and electrovalves are the slaves. The principle of the communication protocol master slave may be resumed like this: the master equipment demands and the slave equipment answers.

The control of the amounts dosed from each sort of wine included in the blending recipe is realized by means of a couple pump-electrovalve for each bin filled with a certain sort of wine. The prompt given by computer for actuating the pump and electrovalve is realized by means of an electronic module in this way

The dosage application calculates the prompt, the communication server sends this through the serial communication line to the electronic module which interprets and transmits the electric prompt corresponding to the selected pump or electrovalve.

The electrovalves are of a special construction adapted to the used liquid (wine). The actuation of the electrovalves is performed with linear electromechanical actuators fig.5 supplied by direct current at a voltage of 24 V.

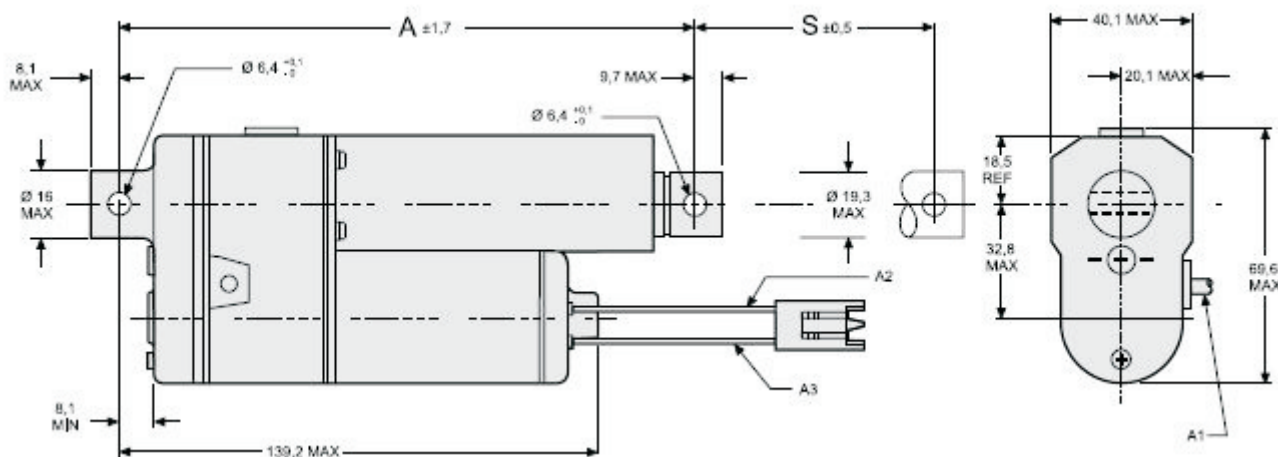
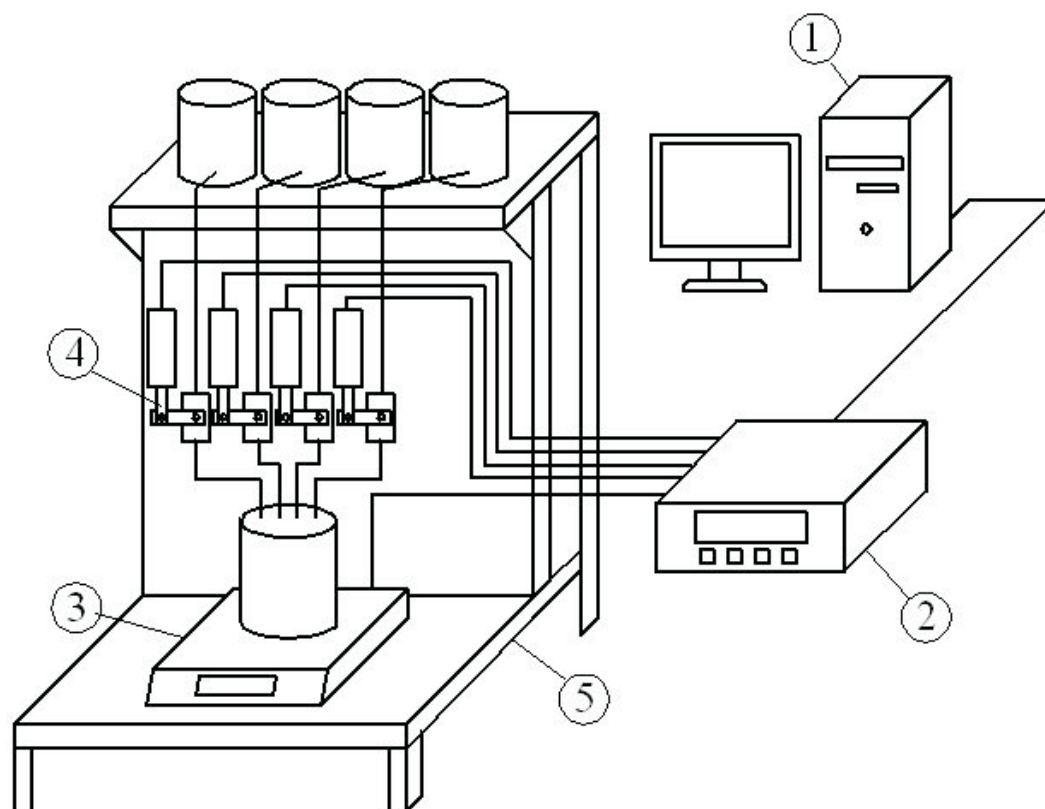

Fig.5 Linear actuator for setting on the electrovalves

The gravimetric batcher is provided with a metallic support on which are fixed the electrovalves and where is placed the electronic scale, the collecting bin and the bins where is made the blending of wine sorts.(fig.6)



- 1 - PC and software
- 2 - Electronic module of control
- 3 - Electronic scale
- 4 - Electrovalves
- 5 - Support structure

Fig.6 The experimental model of the gravimetric batcher of the computerized system used in the process of production of blended wines.